

BOND OF EPOXY-COATED WIRE TO CONCRETE

By

Tony R. Schmitt

David Darwin

A Report on Research Sponsored by

**THE NATIONAL SCIENCE FOUNDATION
Research Grant No. MSS-9021066**

**UNIVERSITY OF KANSAS
LAWRENCE, KANSAS
November 1992**

BOND OF EPOXY-COATED WIRE TO CONCRETE

ABSTRACT

The results of a preliminary study of the bond strength of epoxy-coated and uncoated plain and deformed wire are reported. Bond strength is evaluated using 25 beam-end specimens containing W11 and D11 wire with $\frac{3}{4}$ in. or 2 in. (19 mm or 51 mm) concrete cover. Epoxy coating appears to increase the bond strength of plain wire, while having only a small effect on the bond strength of deformed wire. The tests indicate that epoxy may actually increase the bond strength in cases of high confinement while slightly decreasing the bond strength in cases of lower confinement. The bond strength of both coated and uncoated deformed wire is significantly higher than the bond strength of either coated or uncoated plain wire.

INTRODUCTION

The 1989 ACI Building Code (ACI 318-89) requires an increase in the development length of epoxy-coated reinforcing bars and deformed wire. No modification to development length is required for welded deformed wire fabric. Under the provisions of ACI 318-89, a development length modification factor of 1.5 is required for coated bars and deformed wires with less than 3 bar diameters of concrete cover or less than 6 bar diameters of clear spacing. A factor of 1.2 is required for bars and deformed wires with 3 bar diameters or more of concrete and 6 bar diameters or more of clear spacing. These values are based primarily on the work of Treece and Jirsa (1987, 1989) and their interpretation of tests of beam-end specimens with confined reinforcement by Johnston and Zia (1982). Work at the University of Kansas (Choi et al. 1990a, 1990b, 1991, Hadje-Ghaffari et al. 1991, 1992, Hester et al. 1991) and at Purdue University (Cleary and Ramirez 1989, 1991) indicates that the actual reduction in bond strength due to epoxy coating is less than reflected by the development length modification factors in ACI 318-89.

To date, there are no published tests on the bond strength of epoxy-coated deformed wire or welded deformed wire fabric and concern exists as to whether these provisions should apply to these two reinforcing materials.

This report presents the results of a preliminary study of the bond strength of smooth and deformed wire as affected by epoxy coating. Both smooth and deformed wire were tested to provide a comparison of the potential effects of coating on welded deformed wire fabric as compared to welded plain wire fabric. The investigation is limited to wires of a single diameter and bonded length, with concrete covers of $\frac{3}{4}$ in. or 2 in. (19 mm or 51 mm).

EXPERIMENTAL PROGRAM

The experimental program consisted of three groups of modified cantilever beam-end test specimens. Groups 1 and 2 contained 8 specimens each, while Group 3 contained 9 specimens. A total of 6 specimens each were evaluated for uncoated plain wire, coated plain wire, and coated deformed wire. Seven specimens were evaluated for uncoated deformed wire.

Test Specimens

The beam-end test specimens used to evaluate the bond strength of coated and uncoated W11 and D11 wire were 9 in. (229 mm) wide by 24 in. (610 mm) long by 11 in. (279 mm) deep. A typical test specimen is illustrated in Fig. 1. Specimens in Groups 1 and 2 were cast with a 2 in. (51 mm) cover, while specimens in Group 3 were cast with a $\frac{3}{4}$ in. (19 mm) cover.

The wire projected 24 in. (610 mm) out from the front face of the specimen. Two polyvinylchloride (PVC) pipes were used as bond breakers to limit the bonded length of the wire and to prevent a cone-type failure on the front face of the specimen. The inside diameter of the PVC pipe was slightly larger than the diameter of the wire. The bonded length of the test wire, 3 in. (76 mm), was selected to insure that the wires did not yield before bond failure occurred. The length of the bond-breaking PVC pipe in front of the bonded length (lead length) was $\frac{1}{2}$ in. (13 mm). The joints between the PVC pipe and the wire were sealed with modeling clay.

Materials

Wire.—ASTM A 82 (1990a) plain W11 wire and ASTM A 496 (1990b) deformed D11 steel wire were used. Coating was applied in accordance with ASTM A 884 (1991).

The W11 wire had a unit weight of 0.372 lbs/ft (0.554 kg/m), a diameter of 0.373 in. (9.47 mm), and a cross-sectional area of 0.109 in.² (70.0 mm²). The D11 wire had a unit weight of 0.399 lbs/ft (0.594 kg/m), a nominal diameter of 0.387 in. (9.83 mm), nominal cross-sectional area (measured in accordance with ASTM A 496) of 0.117 in.² (75.5 mm²), an average deformation (indentation) spacing of 0.202 in. (5.13 mm), and an average height of the deformations of 0.024 in. (0.61 mm). The epoxy coating on the W11 wire ranged in thickness from 9.6 to 13.1 mils (1 mil = 0.001 in.) [243 to 333 μ m (1 mil = 25.4 μ m)], with an average value of 11.5 mils (292 μ m), as measured by a pull-off type thickness gauge. The epoxy coating on the D11 wire ranged in thickness from 10.2 to 13.1 mils (259 to 333 μ m), with an average value of 11.8 mils (300 μ m). Readings were taken in accordance with ASTM A 884.

Concrete.—Air-entrained concrete was supplied by a local ready-mix company. Type I

portland cement, 3/4 in. (19 mm) nominal maximum size coarse crushed limestone, and Kansas river sand were used. Water-cement ratios of 0.43 and 0.41 were used to obtain concrete with a nominal strength of at least 4000 psi (27.6 MPa) in two weeks. Mix proportions and concrete properties are shown in Table 1.

Placement Procedure

Concrete was placed in a single lift and vibrated at 6 evenly spaced points within the specimen. Specimens were sprayed with curing compound and covered with plastic. The plastic was removed and the forms were stripped after the concrete had reached a strength of at least 3000 psi (20.7 MPa). Standard 6 x 12 in. (152 x 305 mm) test cylinders were cast in steel molds and cured in the same manner as the test specimens.

Test Procedure

Tests were made at nominal concrete strengths in excess of 4000 psi (27.6 MPa). Flexural bond strength of the wire was measured using an apparatus developed by Donahey and Darwin (1983, 1985) and modified by Brettmann et al. (1984, 1986) (Fig 2). Specimens within each group were tested within a 12-hour period at ages of 12 or 13 days. The wires were loaded at about 0.6 kips/min (2.7 kN/min). During tests of Group 2, the output of one of two load cells used in the system became erratic. Thus, the ultimate bond forces reported for Group 2 are accurate only to ± 0.1 kip (0.4 kN). The problem was corrected for Group 3.

RESULTS, OBSERVATIONS, AND EVALUATION

OF EXPERIMENTAL RESULTS

The test variables and ultimate bond forces for the wires are listed in Table 2. Load-slip curves for each type of wire are illustrated in Figs. 3 and 4.

To compare individual tests on an equitable basis, the ultimate bond forces are corrected for variations in concrete strength by normalizing the test results with respect to a nominal concrete strength of 5000 psi (34.5 MPa), using the assumption that, within the concrete strength range

used, bond strength is proportional to the square root of the compressive strength. Thus, bond strengths are multiplied by $(5000/f'_c)^{1/2}$, f'_c in psi.

Plain Wire

As shown in Table 2 and Fig. 3, coated plain wires consistently provided higher average strengths than uncoated plain wires. Within the three test groups, only in one case (Group 1) did the bond strength on an uncoated smooth wire exceed the strength of either of the coated smooth wires. Load-slip curves for smooth wires (Fig. 3) indicate that both the uncoated and coated wires provide stiff load-slip curves until a peak load is reached, at which point the load drops off with additional slip. However, as shown in Fig. 3, not only is the peak load higher for the coated wires than for the uncoated wires but, after some slip, the coated wires begin to pick up load again, usually reaching a higher load with additional slip. One possibility for this behavior is that, with additional slip, a portion of the test specimen began to cut into the coating, causing a higher measured bond force. However, upon removal of the surrounding concrete, no specific evidence of gouging or damage to the coating was observed. All specimens containing plain wire failed by pullout, without any outward indication of damage to the concrete. The maximum modified bond force for plain wire, 1.114 kips (4.96 kN), was obtained for coated wire with $3/4$ in. (19 mm) cover (Group 3). The minimum modified bond force for plain wire, 0.283 kips (1.26 kN), was obtained for uncoated wire in the same test group.

Deformed Wire

The general shape of the load-slip curves for the uncoated and coated deformed wire were similar, as illustrated in Fig. 4, initially rising steeply, showing some softening near the peak and then slowly dropping off after the peak load was attained. The bond strength provided by both the uncoated and coated deformed wire consistently provided higher bond strengths than the plain wire, with average modified bond forces ranging from 3.86 to 4.99 kips (17.2 to 22.2 kN).

For specimens with 2 in. (51 mm) cover, the coated deformed wire consistently provided a higher bond strength than the uncoated deformed wire, with the coated wire exhibiting average

modified bond forces that were 0.97 and 0.60 kips (4.31 to 2.67 kN) higher than the uncoated wire for Groups 1 and 2, respectively. For the specimens with $\frac{3}{4}$ in. (19 mm) cover, the uncoated wire gave an average modified bond force that was 0.15 kips (0.67 kN) higher than the coated value for wire (Group 3). Thus, in all but one set of comparisons, the coated wire provided higher bond strengths than the uncoated wire, and the lowest ratio of coated to uncoated wire bond strength was 0.95, for the deformed wires in Group 3.

The specimens with a 2 in. (51 mm) cover failed by pullout, with no outward indication of concrete damage, while all of the $\frac{3}{4}$ in. (19 mm) cover specimens failed by concrete splitting. The splitting crack formed vertically over the bar, through the $\frac{3}{4}$ in. (19 mm) cover and along the bonded length of the wire.

After the tests, the wires were removed from the test specimens. A clean surface was observed on the uncoated wires, while concrete was found lodged in the deformations (indentations) of the coated wires. This is opposite to what has been observed for reinforcing bars (Johnston and Zia 1982, Treece and Jirsa, 1987, 1989, Choi et al. 1990a, 1990b, 1991, Hester et al. 1991, Hadje-Ghaffari et al. 1991, 1992). The concrete lodged in the deformations appeared to be stuck in the epoxy coating. In a number of cases, the epoxy at the back of the deformations pulled away from the wire, forming a ball or raised lip at the very end of the deformation and exposing the steel wire within the indentation.

Based on these limited test results, there appear to be some important differences between the behavior of coated wire and coated reinforcing steel. The similarities in the bond strengths of the coated and uncoated deformed wires suggests that the development characteristics of coated welded deformed wire fabric should be very close to the bond strength of uncoated welded deformed wire fabric. The test results strongly support additional research on both deformed wire and welded deformed wire fabric to specifically establish the effect of epoxy coating on these reinforcing materials.

SUMMARY AND CONCLUSIONS

The bond strength of epoxy-coated and uncoated plain and deformed wire was evaluated using beam-end specimens. Twenty-five specimens containing W11 and D11 wire were evaluated.

The following conclusions are based on the results and analyses of these tests.

1. Epoxy coating appears to increase the bond strength of plain wire.
2. Epoxy coating appears to have only a small effect on the bond strength of deformed wire. It may actually increase the bond strength in cases of high confinement while slightly decreasing the bond strength in cases of lower confinement.
3. There appears to be a significant difference in the mechanism of steel-concrete interaction, as affected by epoxy coating, between deformed reinforcing bars and deformed wires with indented deformations.
4. The bond strength of both coated and uncoated deformed wire is significantly higher than the bond strength of either coated or uncoated plain wire.

ACKNOWLEDGMENTS

Funding for this research was provided by National Science Foundation through Grant No. MSS-9021066 under the Research Experience for Undergraduates (REU) program. Wire was supplied by Ivy Steel and Wire Company. O'Brien Nap-Gard 2709 epoxy coating was applied by ABC Coating Co., Inc. Form release agent, curing compound, and mounting hardware were supplied by Richmond Screw Anchor Company.

REFERENCES

- ACI Committee 318. (1989). *Building Code Requirements for Reinforced Concrete (ACI 318-89) and Commentary - ACI 318R-89*, American Concrete Institute, Detroit, MI, 353 pp.
- ASTM. (1990a). "Standard Specification for Steel Wire, Plain, for Concrete Reinforcement," (ASTM A 82-90a) *1992 Annual Book for ASTM Standards*, Vol. 1.04, American Society for

Testing and Materials, Philadelphia, PA, pp. 120-122.

ASTM. (1990b). "Standard Specification for Steel Wire, Deformed, for Concrete Reinforcement," (ASTM A 496-90a) *1992 Annual Book for ASTM Standards*, Vol. 1.04, American Society for Testing and Materials, Philadelphia, PA, pp. 283-286.

ASTM. (1991). "Standard Specification for Epoxy-Coated Steel Wire and Welded Wire Fabric for Reinforcement," (ASTM A 884-91a) *1992 Annual Book for ASTM Standards*, Vol. 1.04, American Society for Testing and Materials, Philadelphia, PA, pp. 621-625.

Brettmann, Barrie B; Darwin, David; and Donahey, Rex C. (1984). "Effect of Superplasticizers on Concrete - Steel Bond Strength," *SL Report 84-1*, University of Kansas Center for Research, Lawrence, Kansas, Apr., 32 pp.

Brettmann, Barrie B; Darwin, David; and Donahey, Rex C. (1986). "Bond of Reinforcement to Superplasticized Concrete," *ACI Journal, Proceedings* Vol. 83, No. 1, Jan.-Feb., pp. 98-107.

Choi, Oan Chul; Hadje-Ghaffari, Hossain; Darwin, David; and McCabe, Steven L. (1990a). "Bond of Epoxy-Coated Reinforcement to Concrete: Bar Parameters," *SL Report 90-1*, Univ. of Kansas Center for Research, Lawrence, Kansas, Jan., 43 pp.

Choi, Oan Chul; Darwin, David; and McCabe, Steven L. (1990b). "Bond Strength of Epoxy-Coated Reinforcement to Concrete," *SM Report No. 25*, Univ. of Kansas Center for Research, Lawrence, Kansas, July, 217 pp.

Choi, Oan Chul; Hadje-Ghaffari, Hossain; Darwin, David; and McCabe, Steven L. (1991). "Bond of Epoxy-Coated Reinforcement: Bar Parameters," *ACI Materials Journal*, Vol. 88, No. 2, Mar.-Apr., pp. 207-217

Cleary, Douglas B. and Ramirez, Julio A. (1989). "Bond of Epoxy Coated Reinforcing Steel in Concrete Bridge Decks," *Joint Highway Research Project Information Report*, JHRP 89-7, Purdue University, 127 pp.

Cleary, Douglas B. and Ramirez, Julio A. (1991). "Bond of Epoxy-Coated Reinforcement," *ACI Materials Journal*, Vol. 88, No. 2, Mar.-Apr., pp. 146-149.

Donahey, Rex C. and Darwin, David. (1983). "Effects of Construction Procedures on Bond in Bridge Decks," *SM Report No. 7*, Univ. of Kansas Center for Research, Lawrence, Kansas, 129 pp.

Donahey, Rex C. and Darwin, David. (1985). "Bond of Top-Cast Bars in Bridge Decks," *Journal of the American Concrete Institute, Proceedings* Vol. 82, No. 1, January-February, pp. 57-66.

Hadje-Ghaffari, Hossain; Darwin, David; and McCabe, Steven L. (1991). "Effects of Epoxy Coating on Bond of Reinforcing Steel to Concrete," *SM Report No. 28*, Univ. of Kansas Center for Research, Lawrence, Kansas, July, 288 pp.

Hadje-Ghaffari, Hossain; Choi, Oan Chul; Darwin, David; and McCabe, Steven L. (1992). "Bond of Epoxy-Coated Reinforcement to Concrete: Cover, Casting Position, Slump, and Consolidation," *SL Report 92-3*, Univ. of Kansas Center for Research, Lawrence, Kansas, June, 42 pp.

Hester, Cynthia J.; Salamizavaregh, Shahin; Darwin, David; and McCabe, Steven L. (1991). "Bond of Epoxy-Coated Reinforcement to Concrete: Splices," *SL Report 91-1*, Univ. of Kansas Center for Research, Lawrence, Kansas, May, 66 pp.

Johnston, David W. and Zia, Paul. (1982). "Bond Characteristics of Epoxy Coated Reinforcing Bars," *Report No. FHWA-NC-82-002*, Center for Transportation Engrg. Studies, Civil Engrg. Dept., North Carolina State Univ., Raleigh, 163 pp.

Treece, Robert A. and Jirsa, James O. (1987). "Bond Strength of Epoxy-Coated Reinforcing Bars," *PMFSEL Report No. 87-1*, Phil M. Ferguson Structural Engineering Laboratory, Univ. of Texas at Austin, Jan., 85 pp.

Treece, Robert A. and Jirsa, James O. (1989). "Bond Strength of Epoxy-Coated Reinforcing Bars," *ACI Materials Journal*, Vol. 86, No. 2, Mar.-Apr., pp. 167-174.

**Table 1a: Concrete Mixture Proportions
(Cubic Yard Batch Weights)**

Group	W/C Ratio	Cement (lb)	Water (lb)	Aggregate		Nominal Air Content (%)
				Fine ⁺ (lb)	Coarse ⁺⁺ (lb)	
1	0.43	520	225	1545	1545	6
2, 3	0.41	550	225	1564	1588	4

+ Kansas River Sand - Lawrence Sand Co., Lawrence, KS, bulk specific gravity (ssd) = 2.62, absorption = 0.5%, fineness modulus = 3.0.

++Crushed limestone - Fogel's Quarry, Ottawa, KS, bulk specific gravity (ssd) = 2.57, absorption = 3.0%, maximum size = 3/4 in., unit weight = 90.5 lb/cu. ft.

Note: 1 lb/yd³ = 0.5933 kg/m³

Table 1b: Concrete Properties

Group	Slump (in.)	Concrete Temperature (F)	Air Content (%)	Age at Test (days)	Compressive Strength (psi)
1	2 1/2	69	5.1	13	4130
2	1 3/4	65	3.2	12	4910
3	2	70	3.2	13	5230

Note: 1 in. = 25.4 mm; 1000 psi = 6.895 MPa

Table 2: Summary of Beam-End Tests

Group	Specimen* Label	Cover (in.)	Concrete Strength (psi)	Ultimate Bond Force (kips)	Modified Bond Force (kips)
1	U1	2 ¹ / ₁₆	4130	0.625	0.688
	U2	2 ¹ / ₈	4130	0.264	0.291
		AVG			0.489
	C1	2 ¹ / ₁₆	4130	1.123	1.236
	C2	2 ¹ / ₁₆	4130	0.486	0.535
		AVG			0.885
	UD1	2 ¹ / ₈	4130	3.139	3.454
	UD2	2 ¹ / ₁₆	4130	3.896	4.487
		AVG			3.870
	CD1	2 ¹ / ₁₆	4130	4.817	5.300
	CD2	2 ¹ / ₁₆	4130	3.987	4.387
		AVG			4.844
2	U1	2 ¹ / ₈	4910	0.054	0.055
	U2	2 ¹ / ₈	4910	0.284	0.287
		AVG			0.171
	C1	2 ¹ / ₁₆	4910	0.030	0.030
	C2	2 ¹ / ₈	4910	0.562	0.567
		AVG			0.299
	UD1	2 ¹ / ₁₆	4910	3.748	3.782
	UD2	2 ¹ / ₈	4910	4.959	5.004
		AVG			4.393
	CD1	2 ¹ / ₁₆	4910	5.145	5.192
	CD2	2 ¹ / ₈	4910	4.747	4.790
		AVG			4.991
3	U1	13 ¹ / ₁₆	5230	0.436	0.417
	U2	13 ¹ / ₁₆	5230	0.156	0.149
		AVG			0.283
	C1	3 ⁴ / ₄	5230	1.040	0.994
	C2	13 ¹ / ₁₆	5230	1.290	1.233
		AVG			1.114
	UD1	13 ¹ / ₁₆	5230	3.888	3.717
	UD2	13 ¹ / ₁₆	5230	4.118	3.937
	UD3	13 ¹ / ₁₆	5230	4.669	4.464
		AVG			4.039
	CD1	13 ¹ / ₁₆	5230	4.113	3.932
	CD2	3 ⁴ / ₄	5230	3.953	3.779
	AVG			3.856	

*Specimen Label

U - Uncoated Plain Wire

C - Coated Plain Wire

CD - Coated Deformed Wire

UD - Uncoated Deformed Wire

** Modified Bond Force = Ult. Bond Force $(5000/f'_c)^{1/2}$

Note: 1 in. = 25.4 mm; 1000 psi = 6.895 MPa; 1 kip = 4.45 kN

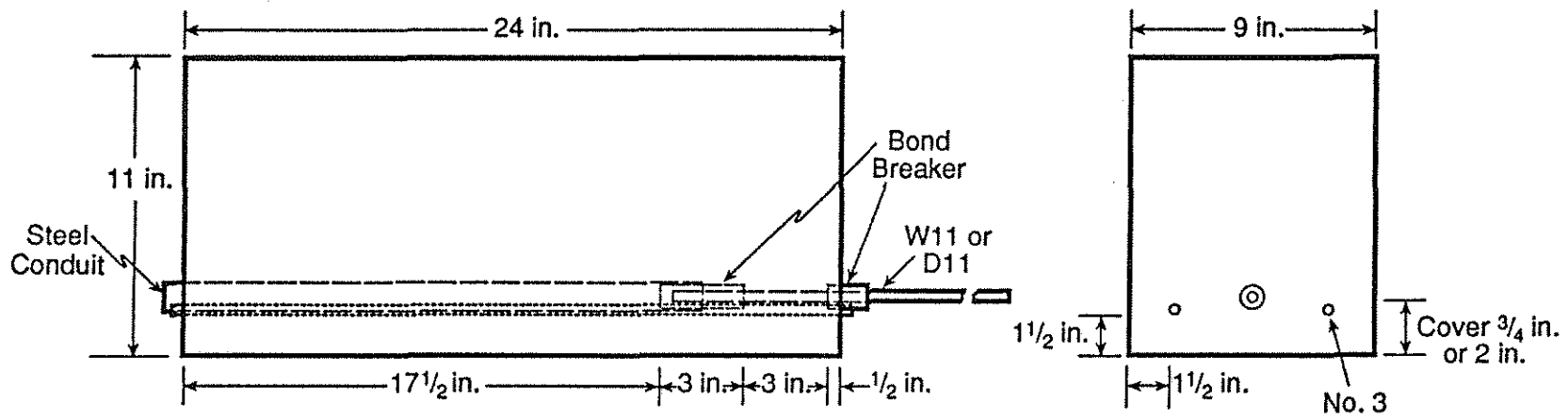

Fig. 1 Beam-end test specimen

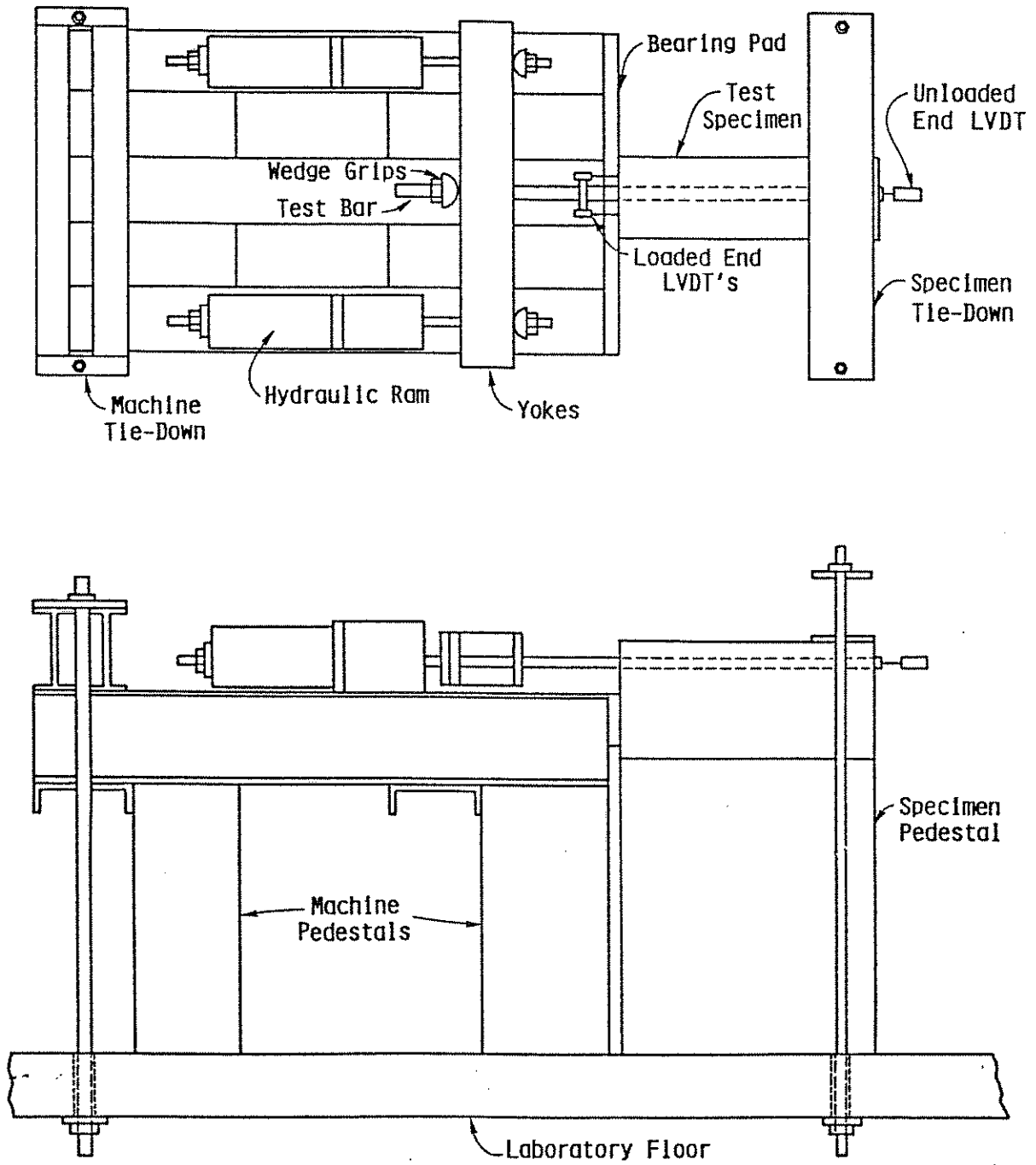

Fig. 2 Schematic of test apparatus (Brettmann, Darwin and Donahey 1984)

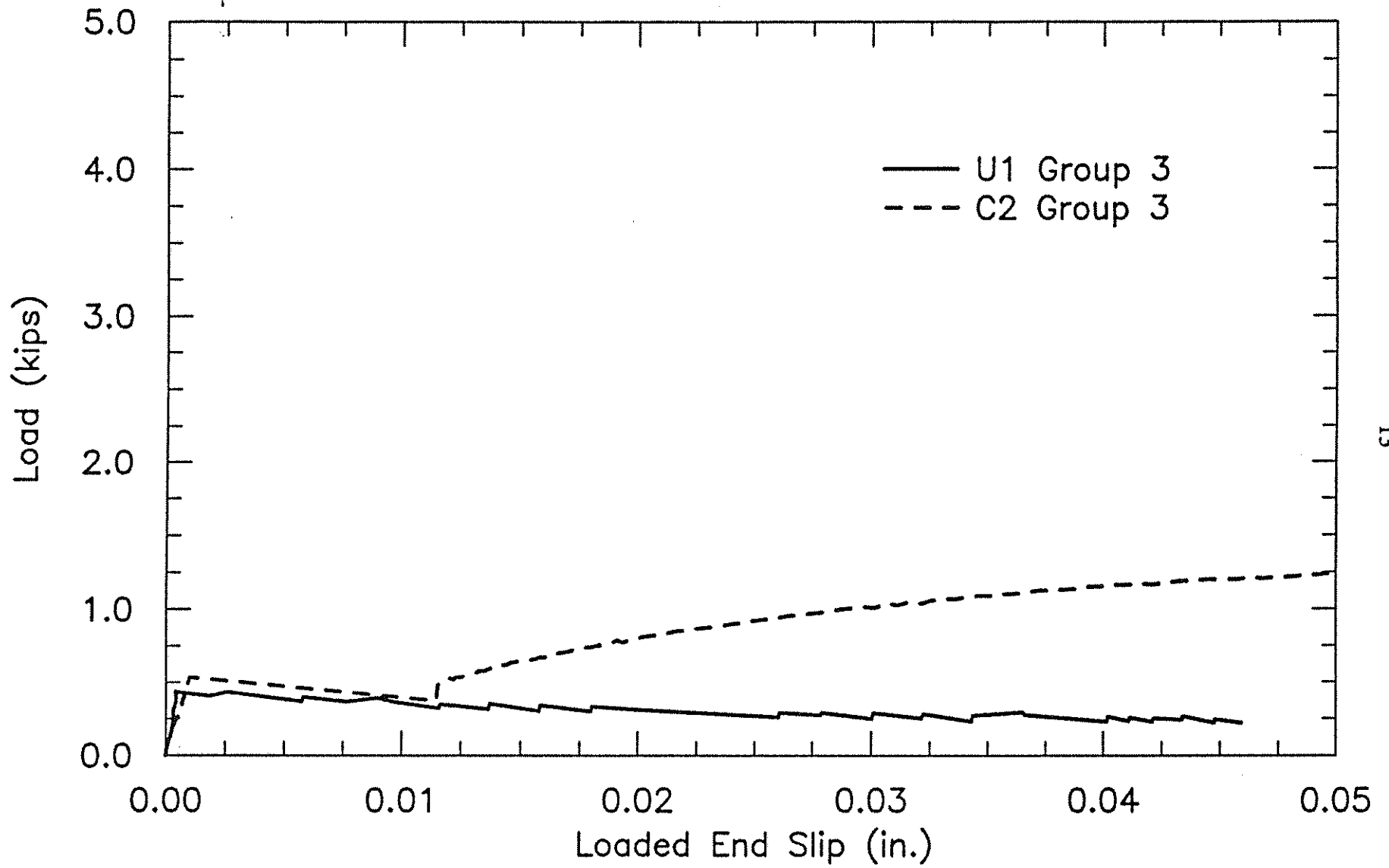

Fig. 3 Load-slip curves for uncoated (U) and coated (C) plain wire (1 in. = 25.4 mm, 1 kip = 4.45 kN)

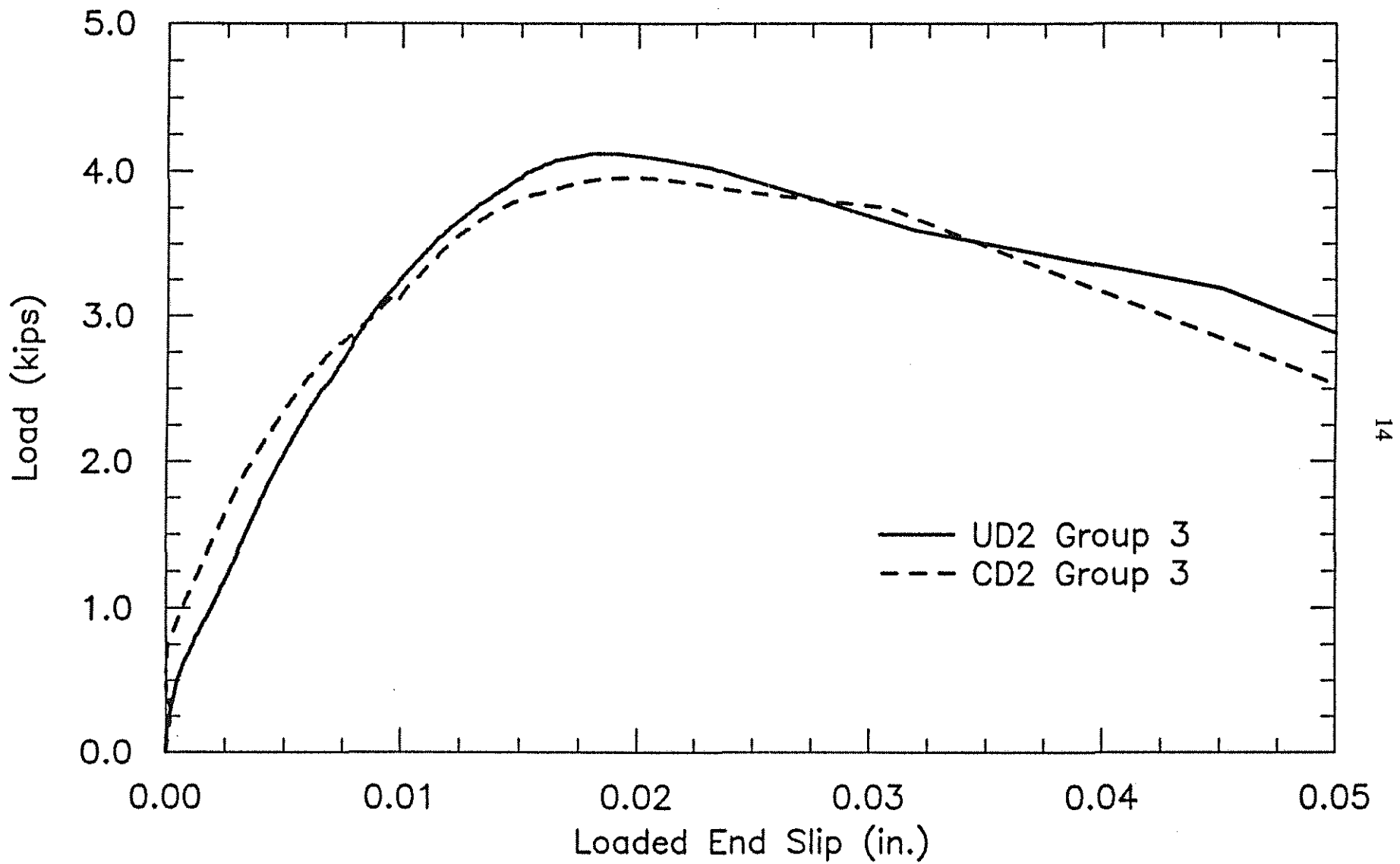

Fig. 4 Load-slip curves for uncoated (UD) and coated (CD) deformed wire (1 in. = 25.4 mm, 1 kip = 4.45 kN)